



BLM0 DC LATCHING SOLENOID

Availability
DC only
PULL & THRUST

Solenoid shown in
energised position

Weight complete 20g
Plunger weight 4g max

Solenoid CLOSSES with
RED Lead + VE
Solenoid OPENS with
BLACK Lead + VE

Minimum Pulse duration - 50ms
De-latch power - 0.5W

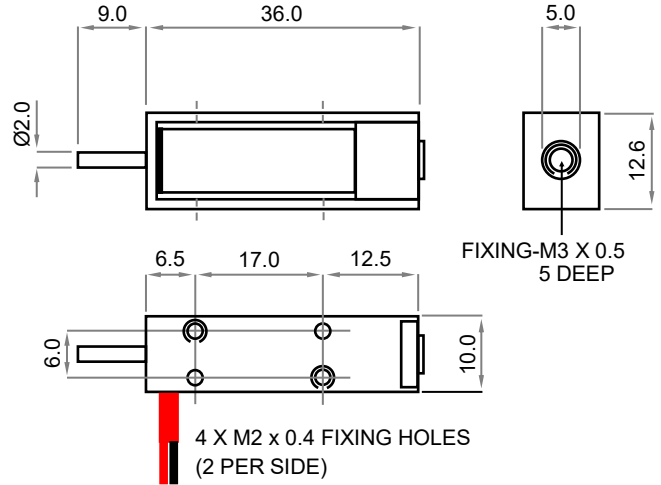

LEADS 200 ONE RED ONE BLACK

DIMENSIONS IN MM

Magnet Holding Force @ '0' stroke - 350g

External force is required when de-latching
Return spring fitted as standard

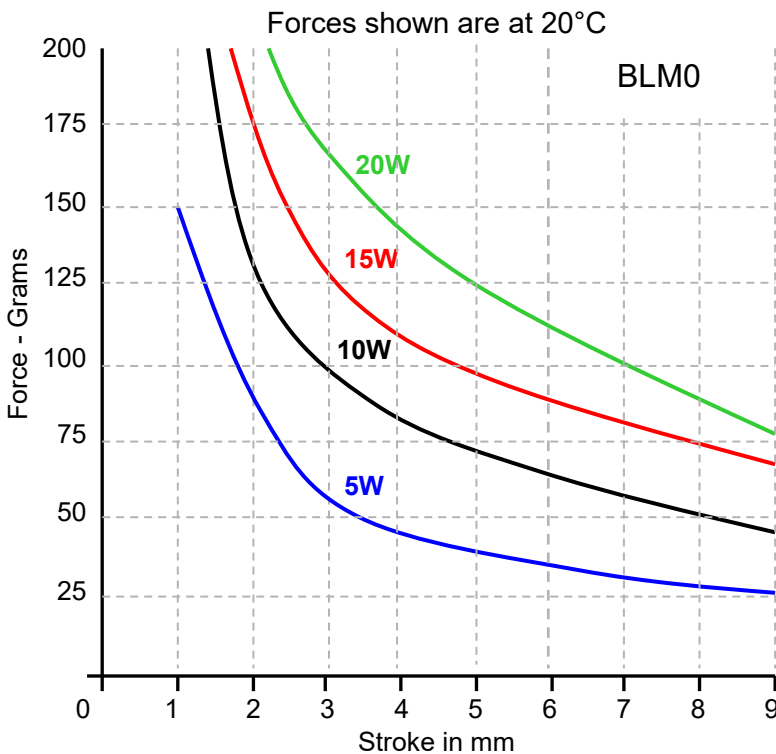

Example Applications

- Electronic Locks
- Medical Cabinets
- Vending Machines
- Battery Operated Locks

** Please note: Fixing, plunger coupling, thrust rods and lead length can all be customised **
We reserve the right to alter or amend designs without prior notice.

HE & BS Benson Ltd

1 Laureate Industrial Estate, Exning Road, Newmarket, Suffolk UK CB8 0AR

☎ +44(0)1638 663535 — 663130 ✉ sales@bensonsolenoids.co.uk 🌐 www.bensonsolenoids.co.uk

CODING

Please use the standard coding below when advising your design requirement.

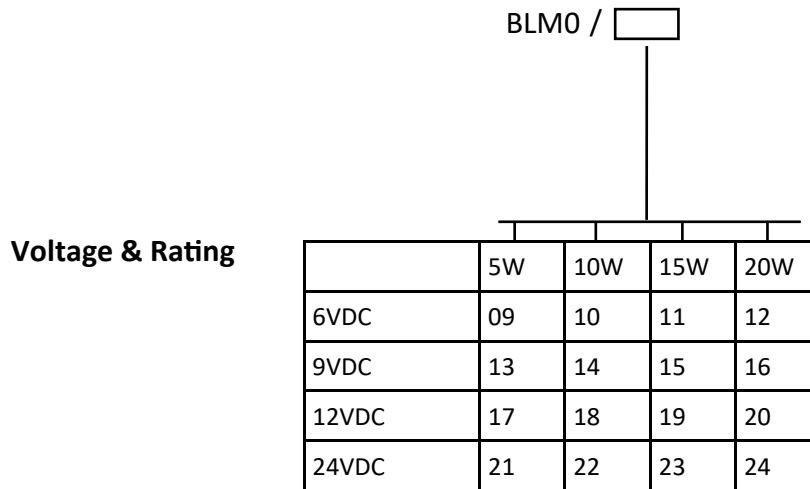

Example - BLM0/19

Other voltages are available on request.

Fixing, plunger coupling, thrust rods and lead length can all be customised.

We reserve the right to alter or amend designs without prior notice.

HE & BS Benson Ltd

1 Laureate Industrial Estate, Exning Road, Newmarket, Suffolk UK CB8 0AR

+44(0)1638 663535 — 663130 ✉ sales@bensonsolenoids.co.uk 🌐 www.bensonsolenoids.co.uk

BLM0 Rev 6 - 2019